

GIF Series Centrifugal Fans

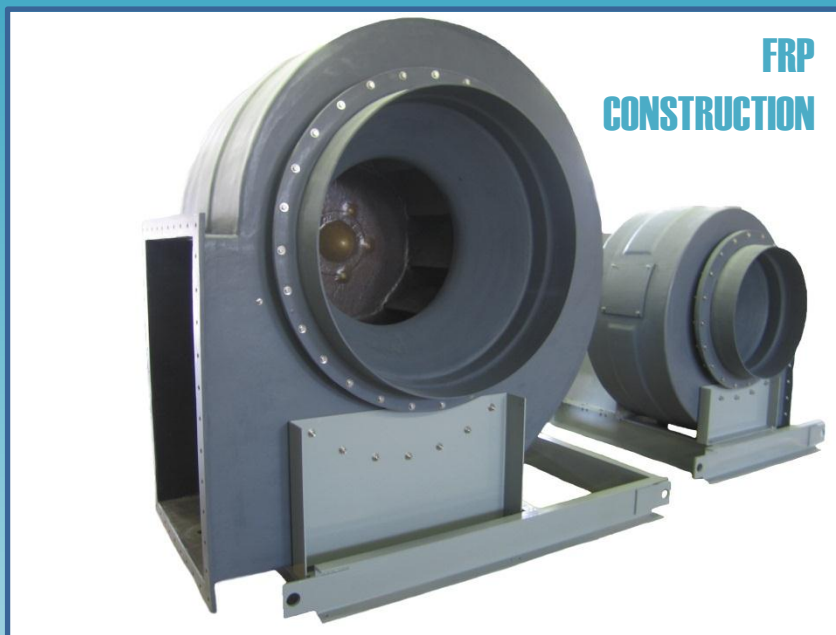

- **Eleven sizes from 24 to 66**
- **Volumes up to 140,000 CFM**
- **Static pressures up to 16" W.G.**
- **Class I** • **Class II** • **Class III**



Plasticair

Introduction

Plasticair's GIF Series has been specifically designed and constructed so that the corrosive gas stream only contacts solid FRP surfaces. The heavy duty backward curved impeller and robust housing offer favourable features such as corrosion resistant FRP construction for all gas contact parts, high efficiencies and quiet operation. The GIF Series is available in eleven sizes and covers volumes up to 140,000 CFM and static pressures up to 16" W.G.

Standard Features

Housing Construction

The fan housing is available in a variety of CW and CCW rotations. The molded smooth surface provides an aerodynamic highly efficient passage for gas streams. Fabrication method is hand lay-up, and materials are vinyl ester resin and reinforcing glass.

Bearings are to be solid pillow block type rated for two hundred thousand hours.

Fasteners are a combination of 304/316 stainless steel.

Flanged outlets are supplied as standard not drilled.

Shaft and Teflon Seal



This effective design has completely protected the polished ground mild steel shaft from the corrosive gas stream. The

shaft is encapsulated with a solid FRP shaft sleeve which protrudes out from the Teflon disk shaft seal located on the housing wall. The Teflon seal shaft sleeve are a machine fit for best possible reduction of leaking gas. 316 stainless steel shafts are available as an option.

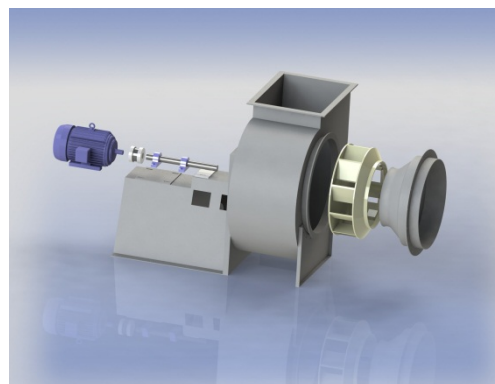

Plasticair Inc. certifies that the GIF series Centrifugal Fans shown herein are licensed to bear the AMCA seal. The ratings shown are based on tests and procedures performed in accordance with AMCA Publication 211 and Publication 311 and Comply with the requirements of the AMCA Certified Ratings Program.



Wheel Construction

The GIF Series is of a high efficiency non-overloading design. The wheel is constructed of solid vinyl ester resin and reinforcing glass. A sprocket and bushing are used for shaft attachment and are completely covered with a minimum 3/16" (5 mm) of FRP lay-up. All gas contact points are FRP complete with corrosion barrier. Plasticair's commitment to quality ensures that only hand lay-up methods are utilized for fabrication. The impeller is comfortably rated to handle up to 17,800 feet per minute (71 m/sec) tip speed.

Accessories

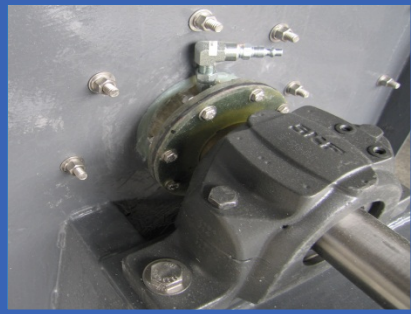

Mechanical Shaft Seals – Zero Leakage: For critical toxic applications mechanical gas purge seals in FRP construction are available on all Plasticair fans in arrangements 1, 8, 9. This seal is located where the shaft meets the fan scroll wall. This seal works up to the fan static pressure capacity. External supply of gas is required by other.



Silencer/GIF Packaged Systems: Plasticair offers a wide range of corrosion resistant fan/silencer packaged systems. Other options are fan scroll added thickness, FRP sound enclosures/penthouses. All construction is focused on the highest attenuation while maintaining corrosion resistance.



Outdoor Weather Guard: For outdoor installations Plasticair's FRP weather guard is designed for not only protecting the fan against outdoor elements but also serving as an OSHA rated belt and shaft guard.

- Inlet flanges
- Inlet and outlet FRP companion flanges
- Flame retardant construction:
Per ASTM E84 - 0-25 Flame Spread.
- Access Door
- V-belt drive selections
- Direct drive couplings
- Indoor belt guards
- PVC drain – Threaded NPT
- FRP drain – flanged and drilled
- Bearing upgrade – split pillow block bearings available upon request
- Shaft material upgrades – 304 ss, 316 ss, Titanium
- FRP Gravity operated back draft dampers.
- Fan stand coatings - FRP (the zero rust solution) 0.1875" thickness (4.8 mm thickness)
- Fan stand coatings - Epoxy 4-6 mils
- Fan stand coatings - Epoxy 8-10 mils
- Fan stand coatings - Epoxy 12-14 mils
- Nexus linings (for Hydrofluoric Acid applications)
- Spark resistant - graphite lined FRP with grounding kit (Equal to AMCA – A)
- Vibration isolators: spring housed
- Vibration isolators: spring housed & restrained
- Vibration isolators: neoprene mounts
- Inlet screens
- Added thickness to fan housing for sound reduction

Alternate Drive Arrangements

ARRANGEMENT 1

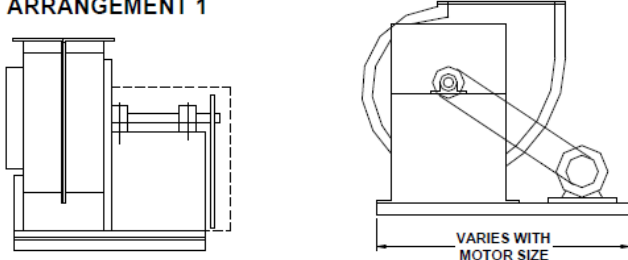

VARIES WITH MOTOR SIZE

MOTOR MAY BE LEFT OR RIGHT HAND MOUNTED



ARRANGEMENT 4

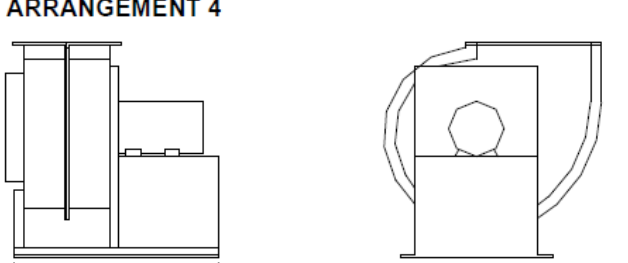

VARIES WITH MOTOR SIZE



ARRANGEMENT 8

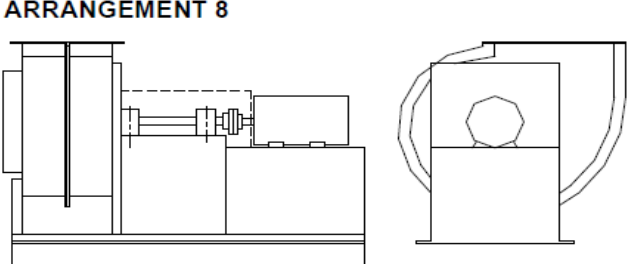

VARIES WITH MOTOR SIZE



ARRANGEMENT 9

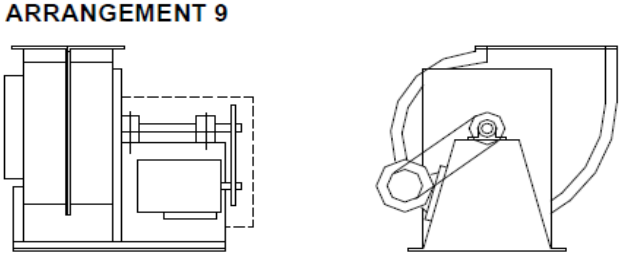

MOTOR MAY BE LEFT OR RIGHT HAND MOUNTED



ARRANGEMENT 10

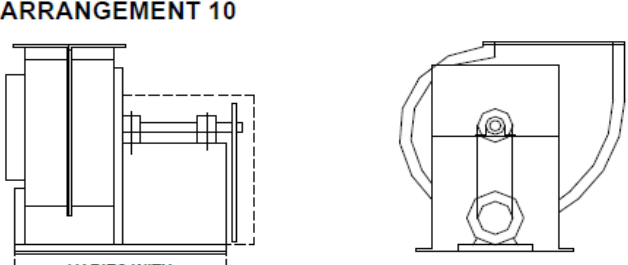

VARIES WITH MOTOR SIZE



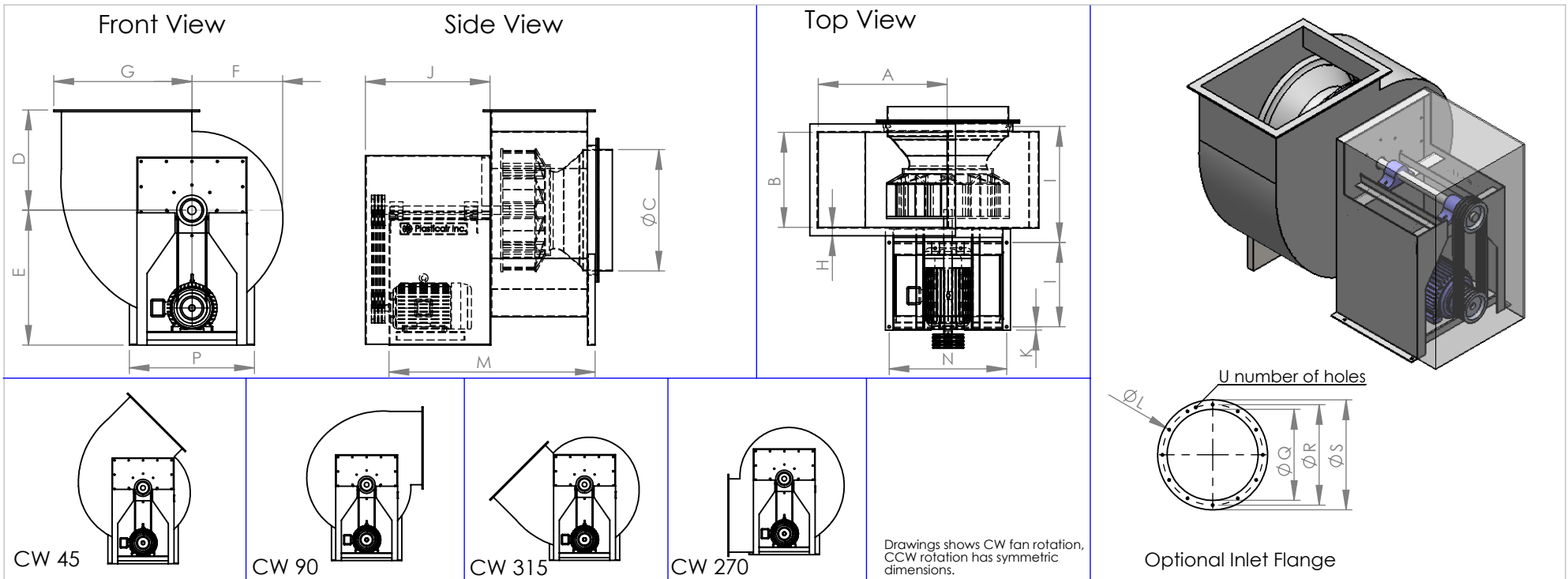

Size	A	B	C	D	E	F	G	H	I	J	K	L	M	N	P	Q	R	S	U
24 GIF	25.750	19.25	24.00	19.25	32.25	21.00	28.25	2.5	21.0	32.50	2.0	0.50	46	30.0	29.375	24.00	26.50	29.00	12
27 GIF	28.375	21.187	27.00	21.25	34.875	22.875	30.875	2.5	22.5	34.00	2.0	0.50	49	33.0	29.375	27.00	29.50	32.00	12
30 GIF	31.50	23.562	30.00	23.625	39.00	25.125	34.00	2.5	24.0	36.00	2.0	0.625	52	37.0	37.875	30.00	33.00	36.00	16
33 GIF	34.625	25.937	33.00	25.875	42.125	27.50	37.125	2.5	25.0	37.50	2.5	0.625	55	40.0	40.875	33.00	36.00	39.00	16
36 GIF	38.375	28.687	36.00	28.625	45.875	30.00	40.875	2.5	26.0	40.00	3.5	0.625	59	44.0	45.875	36.00	39.00	42.00	16
40 GIF	42.250	31.625	40.00	31.625	50.25	33.50	45.25	3.0	28.0	42.00	3.5	0.625	63	48.0	49.25	40.00	43.00	46.00	16
44 GIF	46.750	34.937	44.00	35.00	54.75	36.625	49.75	3.0	31.5	47.50	3.5	0.625	70	53.0	53.50	44.00	47.00	50.00	16
49 GIF	51.50	38.875	49.00	38.50	60.50	40.00	54.50	3.0	34.5	51.00	3.5	0.625	76	58.5	59.00	49.00	52.00	55.00	16
54 GIF	57.00	42.625	54.00	42.625	66.00	44.00	60.00	3.0	37.0	53.50	3.5	0.625	81	64.5	64.00	54.00	57.00	60.00	16
60 GIF	63.00	47.125	60.00	47.125	74.00	48.50	66.00	3.0	39.5	57.00	4.5	0.625	88	72.0	66.50	60.00	63.00	66.00	16
66 GIF	69.375	51.875	66.00	51.875	80.375	52.875	72.375	3.0	42.5	61.00	4.5	0.625	94	78.5	68.50	66.00	69.00	72.00	16

Standard Options:
 Solid FRP Housing
 Fan Stand- Arr10, Epoxy Coated
 Drive & Shaft Guard
 Impeller - Backward Inclined, FRP
 Shaft- 1045 Carbon Steel with FRP Sleeve
 Fasteners - SS 304/SS316
 Bearings - Solid Pillow Block/200,000 h L10 life
 Teflon Seal & Shaft Sleeve
 Outlet Connection - Flanged (not drilled)
 Inlet Connection - Slip Type
 Wheel Width: 100%

Due to product improvement and development Plasticair reserves the right to change design and construction at any time without notice.

Note: Dimensions are not used for construction, certified drawings available upon request

PROPRIETARY AND CONFIDENTIAL

THE INFORMATION CONTAINED IN THIS DRAWING IS THE SOLE PROPERTY OF PLASTICAIR INC. ANY REPRODUCTION IN PART OR AS A WHOLE WITHOUT THE WRITTEN PERMISSION OF PLASTICAIR INC. IS PROHIBITED.



UNLESS OTHERWISE SPECIFIED:		NAME	DATE	TITLE: GIF ARR. 10 SWSI
DRAWN		Y.I.	Oct 2 2012	
DIMENSIONS ARE IN INCHES TOLERANCES: FRACTIONAL ± 0.25" ANGULAR: MACH ± BEND ± TWO PLACE DECIMAL ± THREE PLACE DECIMAL ±		CHECKED		
		ENG APPR.		
		MFG APPR.		SIZE
		Q.A.		A
			DWG. NO.	REV
				1

Front View

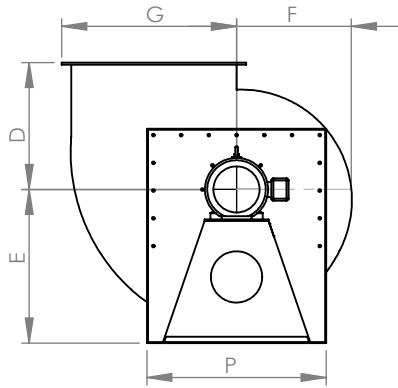

Side View

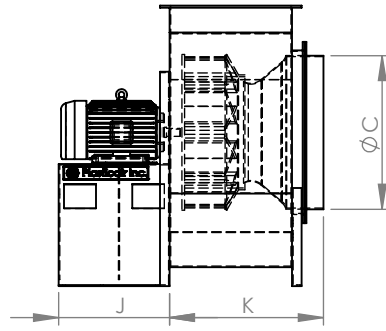

Top View

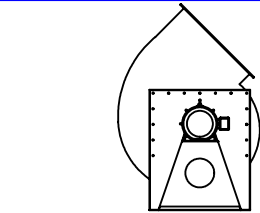
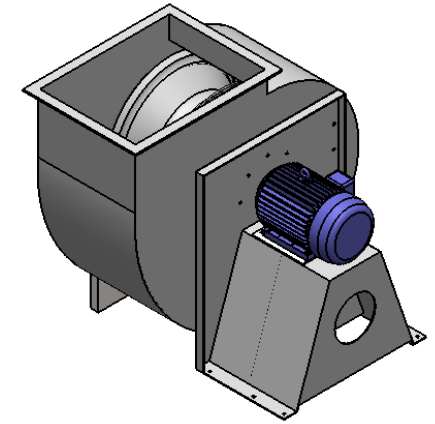
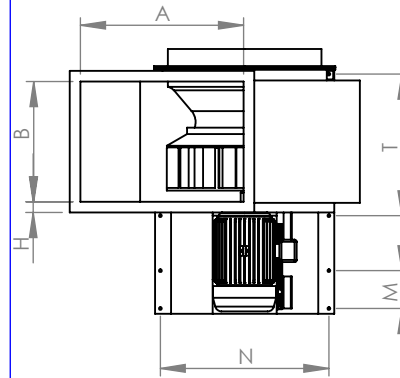

CW 45

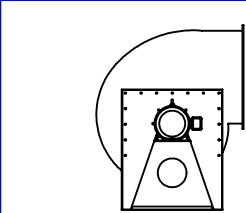

CW 90

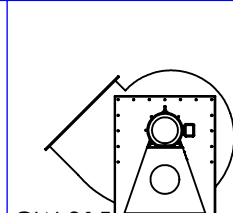

CW 315

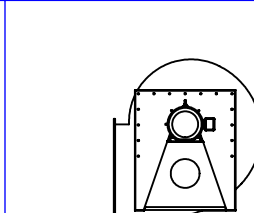

CW 270

Drawings shows CW fan rotation.
CCW rotation has symmetric dimensions.

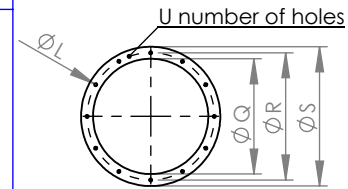

Optional Inlet Flange

Size	A	B	C	D	E	F	G	H	J	K	L	M	N	P	Q	R	S	T	U
24 GIF	25.750	19.25	24.00	19.25	29.625	21.00	28.25	2.5	20.00	25.250	0.50	8.00	26.875	29.375	24.00	26.50	29.00	22.375	12
27 GIF	28.375	21.187	27.00	21.25	32.375	22.875	30.875	2.5	24.00	27.312	0.50	10.00	26.875	29.375	27.00	29.50	32.00	23.875	12
30 GIF	31.50	23.562	30.00	23.625	35.625	25.125	34.00	2.5	24.00	30.00	0.625	10.00	35.875	37.875	30.00	33.00	36.00	26.25	16
33 GIF	34.625	25.937	33.00	25.875	38.875	27.50	37.125	2.5	26.00	33.437	0.625	11.00	38.875	40.875	33.00	36.00	39.00	29.25	16
36 GIF	38.375	28.687	36.00	28.625	42.75	30.00	40.875	2.5	26.00	35.937	0.625	11.00	43.375	45.875	36.00	39.00	42.00	31.375	16
40 GIF	42.250	31.625	40.00	31.625	46.75	33.50	45.25	3.0	28.00	39.375	0.625	12.00	46.750	49.25	40.00	43.00	46.00	34.312	16
44 GIF	46.750	34.937	44.00	35.00	46.75	36.625	49.75	3.0	36.00	44.125	0.625	15.50	51.00	53.50	44.00	47.00	50.00	37.50	16
49 GIF	51.50	38.875	49.00	38.50	48.00	40.00	54.50	3.0	38.00	47.50	0.625	16.50	56.50	59.00	49.00	52.00	55.00	41.437	16
54 GIF	57.00	42.625	54.00	42.625	53.00	44.00	60.00	3.0	40.00	53.125	0.625	17.50	61.50	64.00	54.00	57.00	60.00	46.187	16
60 GIF	63.00	47.125	60.00	47.125	58.00	48.50	66.00	3.0	40.00	57.625	0.625	17.50	64.00	66.50	60.00	63.00	66.00	50.75	16
66 GIF	69.375	51.875	66.00	51.875	60.00	52.875	72.375	3.0	40.00	62.375	0.625	17.50	66.00	68.50	66.00	69.00	72.00	55.50	16

Standard Options:

- Solid FRP Housing
- Fan Stand- Arr4, Epoxy Coated
- Drive & Shaft Guard
- Impeller - Backward Inclined, FRP
- Shaft- 1045 Carbon Steel with FRP Sleeve
- Fasteners - SS 304/SS316
- Bearings - Solid Pillow Block/200,000 h L10 life
- Teflon Seal & Shaft Sleeve
- Outlet Connection - Flanged (not drilled)
- Inlet Connection - Slip Type
- Wheel Width: 100%

Due to product improvement and development Plasticair reserves the right to change design and construction at any time without notice

Note: Dimensions are not used for construction, certified drawings available upon request

PROPRIETARY AND CONFIDENTIAL

THE INFORMATION CONTAINED IN THIS DRAWING IS THE SOLE PROPERTY OF PLASTICAIR INC. ANY REPRODUCTION IN PART OR AS A WHOLE WITHOUT THE WRITTEN PERMISSION OF PLASTICAIR INC. IS PROHIBITED.



UNLESS OTHERWISE SPECIFIED:

DIMENSIONS ARE IN INCHES
TOLERANCES:
FRACTIONAL ± 0.25"
ANGULAR: MACH ± BEND ±
TWO PLACE DECIMAL ±
THREE PLACE DECIMAL ±

NAME	DATE	TITLE: GIF ARR. 4 SWSI	SIZE A	DWG. NO.	REV 1	
DRAWN	Y.I.					Oct 2 2012
CHECKED	ENG APPR.					
MFG APPR.	Q.A.					

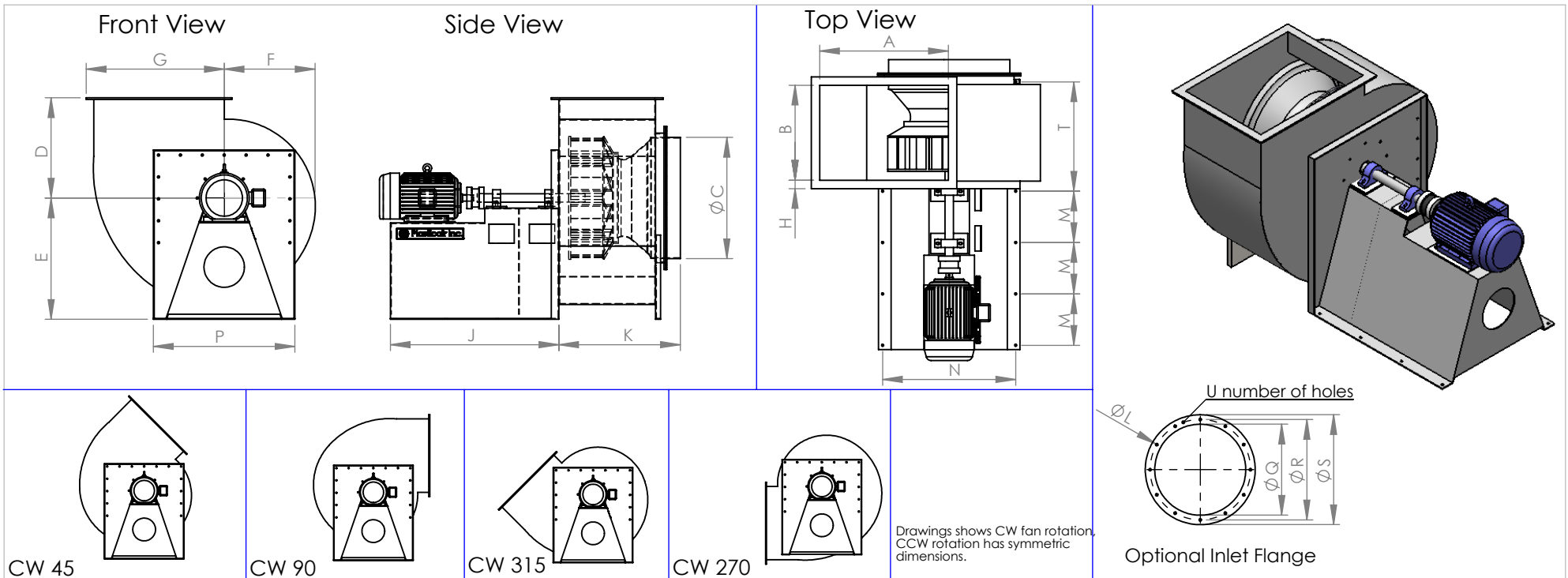

Size	A	B	C	D	E	F	G	H	J	K	L	M	N	P	Q	R	S	T	U
24 GIF	25.750	19.25	24.00	19.25	25.00	21.00	28.25	2.5	45.00	25.25	0.50	14.00	30.125	32.125	24.00	26.50	29.00	22.375	12
27 GIF	28.375	21.187	27.00	21.25	27.00	22.875	30.875	2.5	45.00	27.312	0.50	14.00	32.875	34.875	27.00	29.50	32.00	23.875	12
30 GIF	31.50	23.562	30.00	23.625	30.00	25.125	34.00	2.5	50.00	30.00	0.625	15.625	35.875	37.875	30.00	33.00	36.00	26.25	16
33 GIF	34.625	25.937	33.00	25.875	33.00	27.50	37.125	2.5	50.00	33.437	0.625	15.625	38.875	40.875	33.00	36.00	39.00	29.25	16
36 GIF	38.375	28.687	36.00	28.625	36.00	30.00	40.875	2.5	52.00	35.937	0.625	16.25	43.375	45.875	36.00	39.00	42.00	31.375	16
40 GIF	42.250	31.625	40.00	31.625	40.00	33.50	45.25	3.0	52.00	39.375	0.625	16.25	46.750	49.25	40.00	43.00	46.00	34.312	16
44 GIF	46.750	34.937	44.00	35.00	44.00	36.625	49.75	3.0	60.375	44.125	0.625	18.75	51.00	53.50	44.00	47.00	50.00	37.50	16
49 GIF	51.50	38.875	49.00	38.50	48.00	40.00	54.50	3.0	60.375	47.50	0.625	18.75	56.50	59.00	49.00	52.00	55.00	41.437	16
54 GIF	57.00	42.625	54.00	42.625	53.00	44.00	60.00	3.0	68.375	53.125	0.625	21.375	61.50	64.00	54.00	57.00	60.00	46.187	16
60 GIF	63.00	47.125	60.00	47.125	58.00	48.50	66.00	3.0	70.00	57.625	0.625	22.00	64.00	66.50	60.00	63.00	66.00	50.75	16
66 GIF	69.375	51.875	66.00	51.875	60.00	52.875	72.375	3.0	72.00	62.375	0.625	22.50	66.00	68.50	66.00	69.00	72.00	55.50	16

Standard Options:

- Solid FRP Housing
- Fan Stand- Arr8, Epoxy Coated
- Drive & Shaft Guard
- Impeller - Backward Inclined, FRP
- Shaft- 1045 Carbon Steel with FRP Sleeve
- Fasteners - SS 304/SS316
- Bearings - Solid Pillow Block/200,000 h L10 life
- Teflon Seal & Shaft Sleeve
- Outlet Connection - Flanged (not drilled)
- Inlet Connection - Slip Type
- Wheel Width: 100%

Due to product improvement and development Plasticair reserves the right to change design and construction at any time without notice

Note: Dimensions are not used for construction, certified drawings available upon request

PROPRIETARY AND CONFIDENTIAL

THE INFORMATION CONTAINED IN THIS DRAWING IS THE SOLE PROPERTY OF PLASTICAIR INC. ANY REPRODUCTION IN PART OR AS A WHOLE WITHOUT THE WRITTEN PERMISSION OF PLASTICAIR INC. IS PROHIBITED.



UNLESS OTHERWISE SPECIFIED:		NAME	DATE	TITLE: GIF ARR. 8 SWSI
DRAWN		Y.I.	Oct 2 2012	
CHECKED ENG APPR.				
MFG APPR.				
Q.A.				SIZE A
		DWG. NO.		REV 1

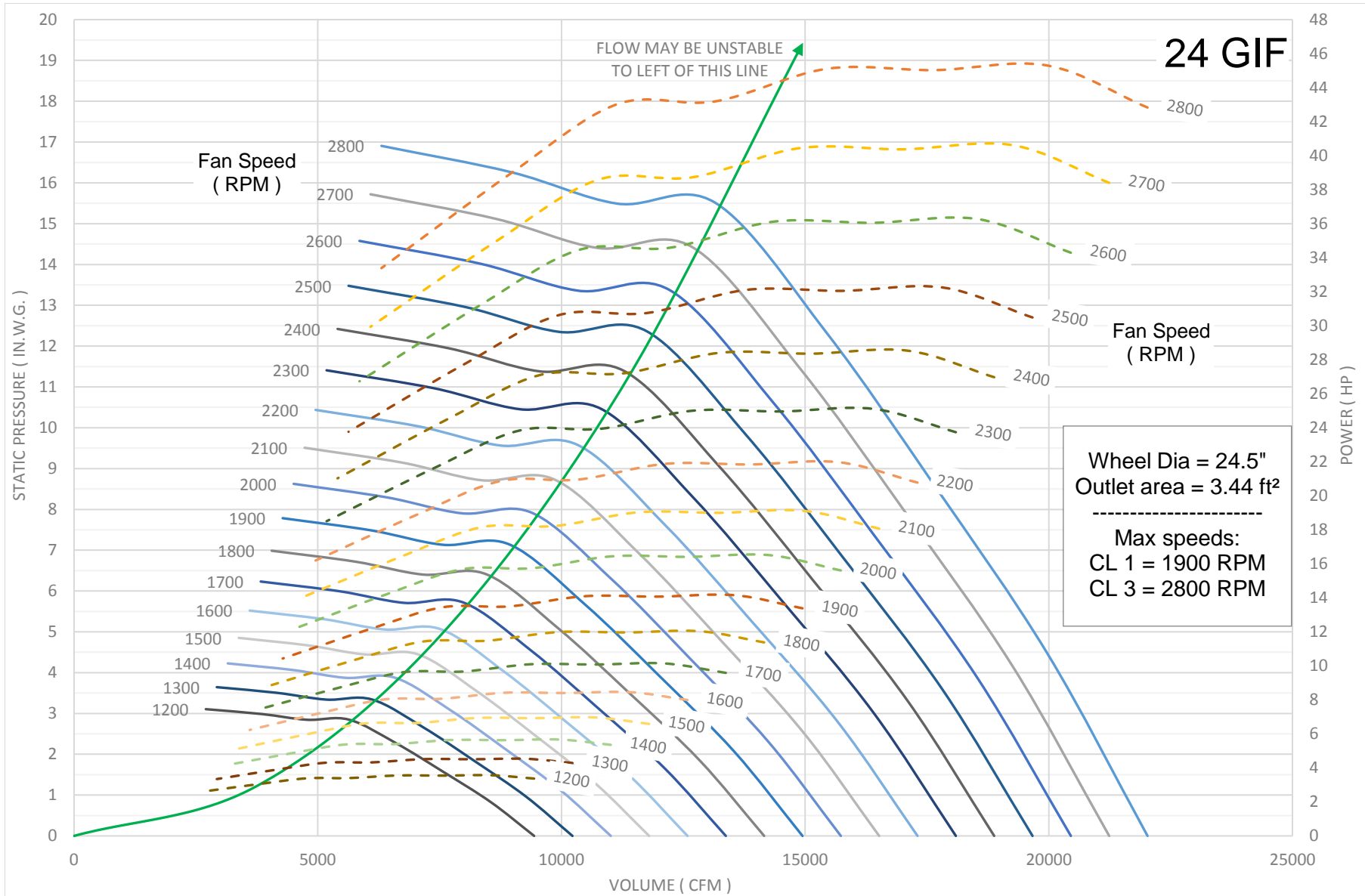

Plasticair Inc.
1275 Crestlawn Drive
Mississauga, Ontario L4W 1A9

PERFORMANCE CERTIFIED IS FOR INSTALLTION TYPE B - UNDUCTED INLET, DUCTED OUTLET
PERFORMANCE RATINGS DO NOT INLDUE THE EFFECTS OF APPARTENACES (ACCESSORIES)
POWER RATINGS DO NOT INLCLUDE TRANSMISSION LOSSES

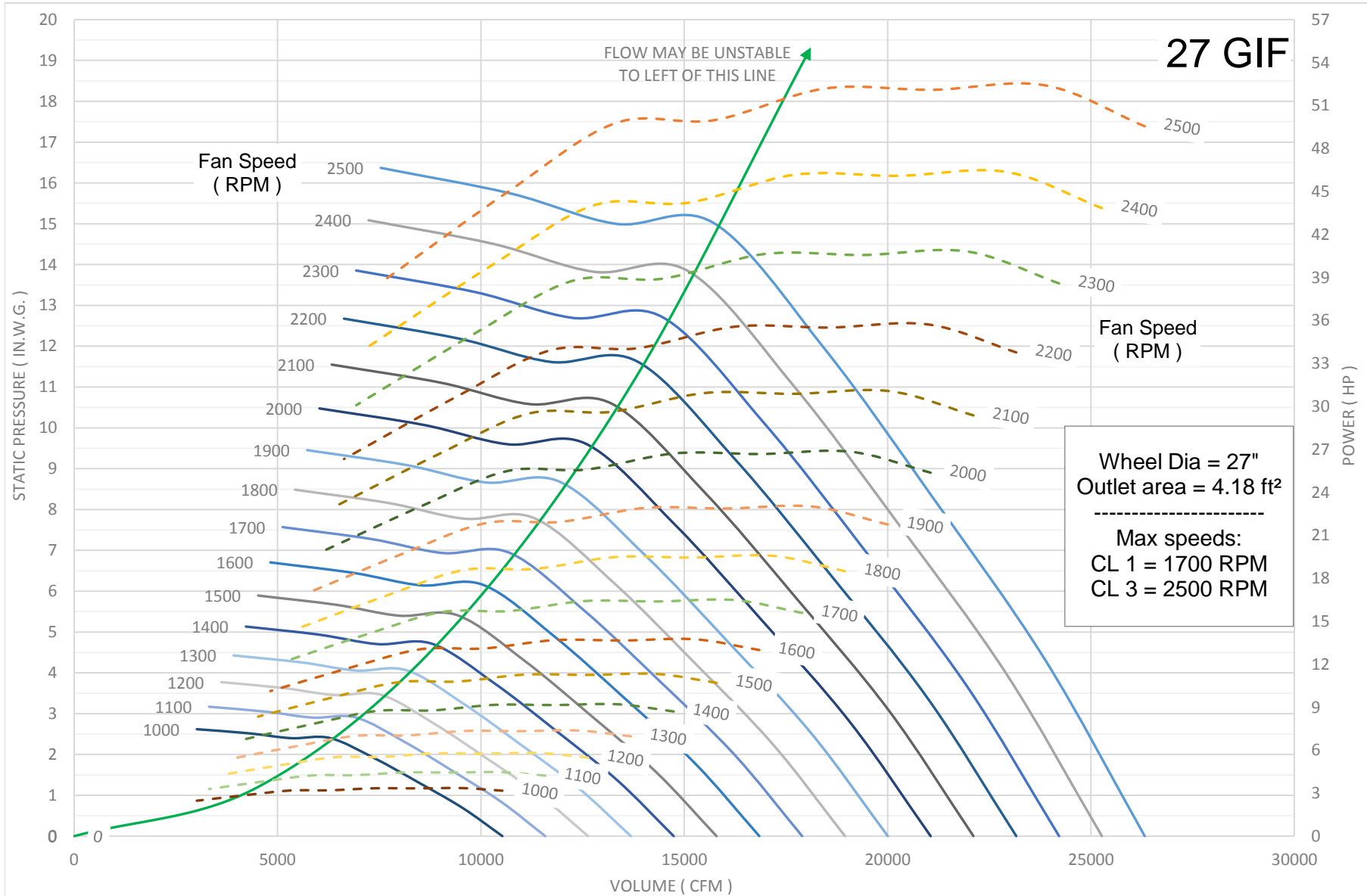

Plasticair Inc.
1275 Crestlawn Drive
Mississauga, Ontario L4W 1A9

PERFORMANCE CERTIFIED IS FOR INSTALLTION TYPE B - UNDUCTED INLET, DUCTED OUTLET
 PERFORMANCE RATINGS DO NOT INLDUE THE EFFECTS OF APPARTENACES (ACCESSORIES)
 POWER RATINGS DO NOT INLCUDE TRANSMISSION LOSSES

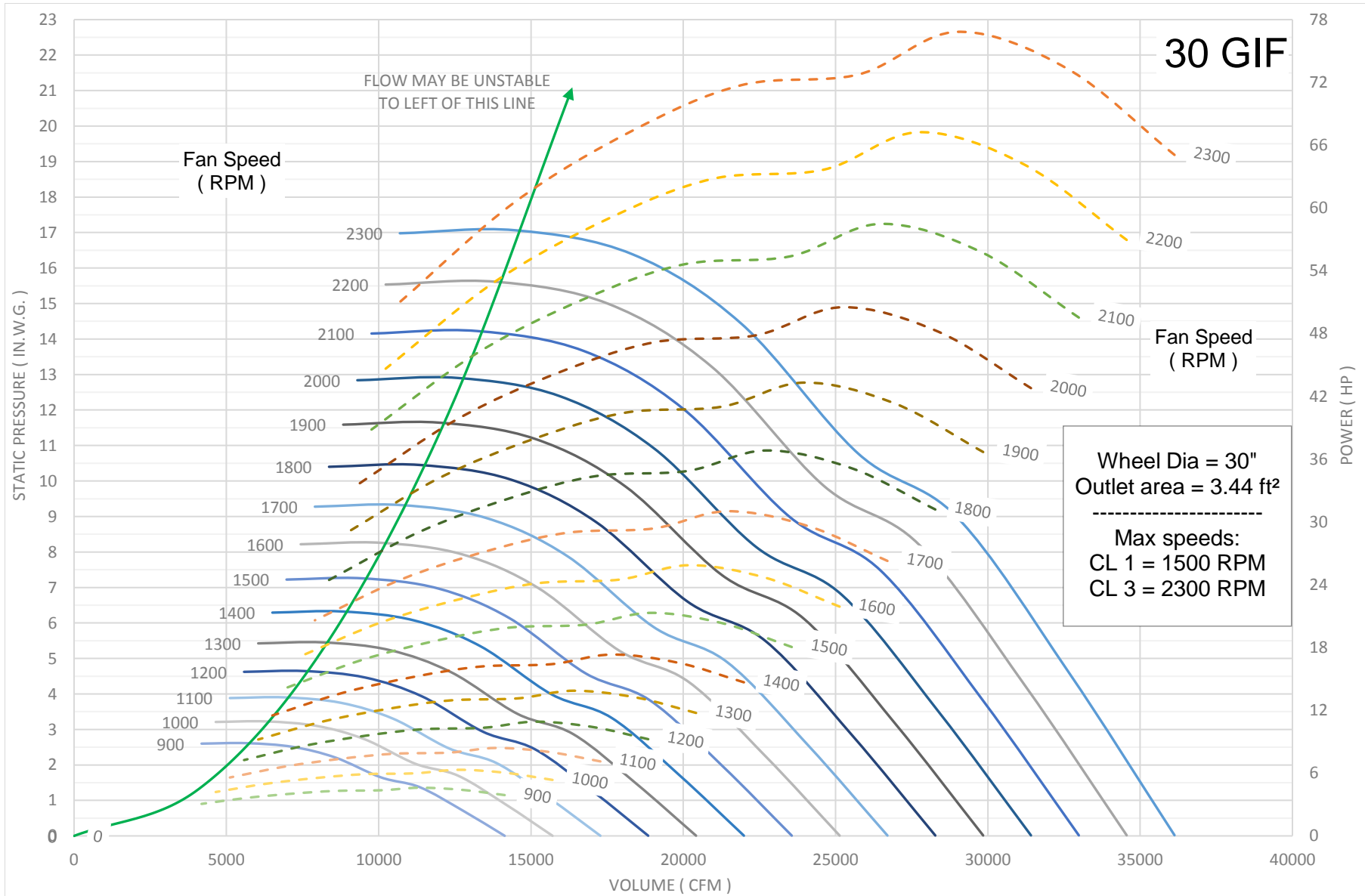

Plasticair Inc.
 1275 Crestlawn Drive
 Mississauga, Ontario L4W 1A9

PERFORMANCE CERTIFIED IS FOR INSTALLTION TYPE B - UNDUCTED INLET, DUCTED OUTLET
 PERFORMANCE RATINGS DO NOT INLDUE THE EFFECTS OF APPARTENACES (ACCESSORIES)
 POWER RATINGS DO NOT INLCLUDE TRANSMISSION LOSSES

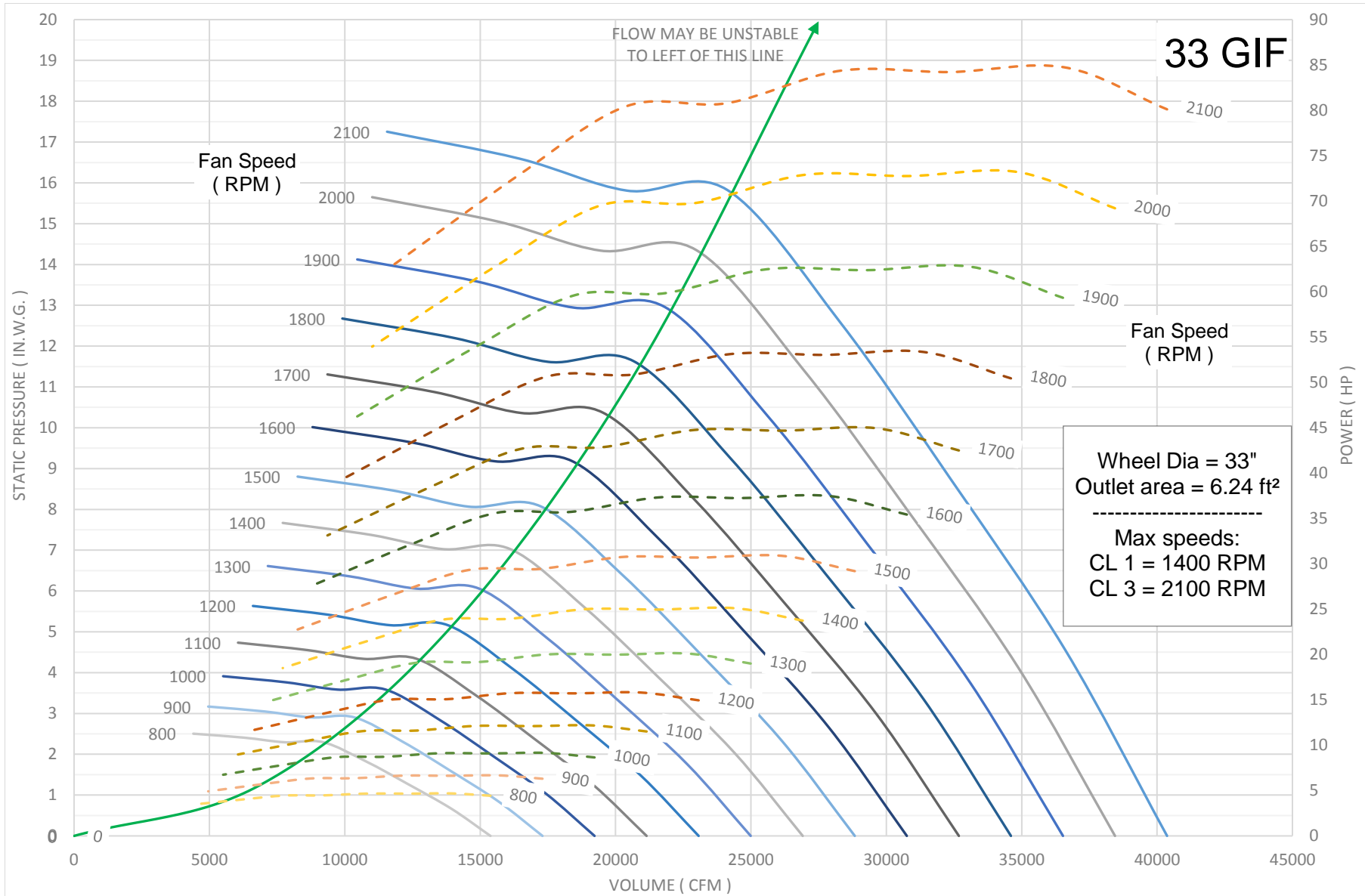

Plasticair Inc.
1275 Crestlawn Drive
Mississauga, Ontario L4W 1A9

PERFORMANCE CERTIFIED IS FOR INSTALLTION TYPE B - UNDUCTED INLET, DUCTED OUTLET
PERFORMANCE RATINGS DO NOT INLDUE THE EFFECTS OF APPARTENACES (ACCEESSORIES)
POWER RATINGS DO NOT INCLLUDE TRANSMISSION LOSSES

36 GIF

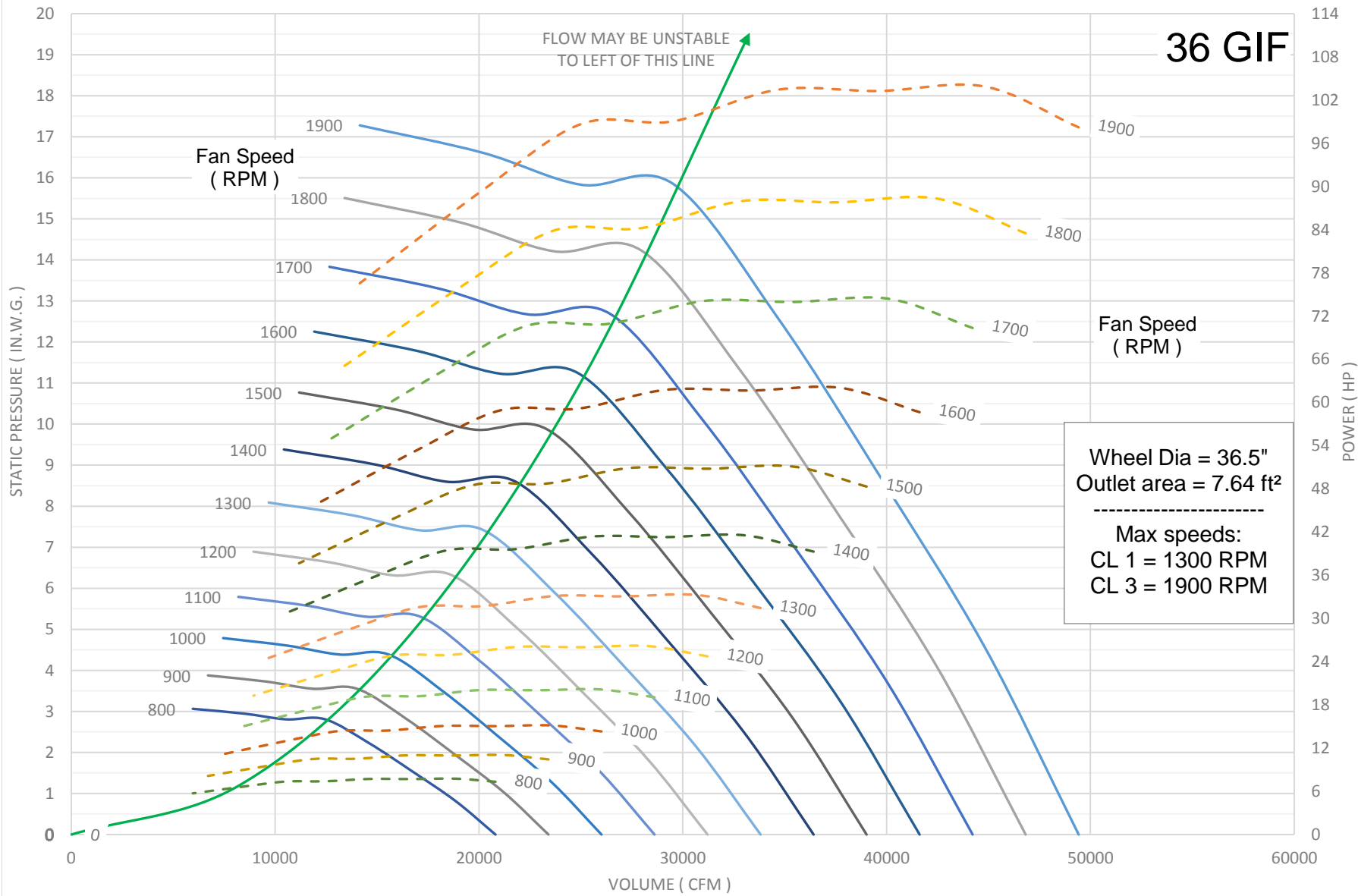

Plasticair Inc.
 1275 Crestlawn Drive
 Mississauga, Ontario L4W 1A9

PERFORMANCE SHOWN IS FOR INSTALLATION TYPE B - UNDUCTED INLET, DUCTED OUTLET.
 PERFORMANCE RATINGS DO NOT INCLUDE THE EFFECTS OF APPURTENANCES (ACCESSORIES).
 POWER RATINGS DO NOT TRANSMISSION DRIVE LOSSES.

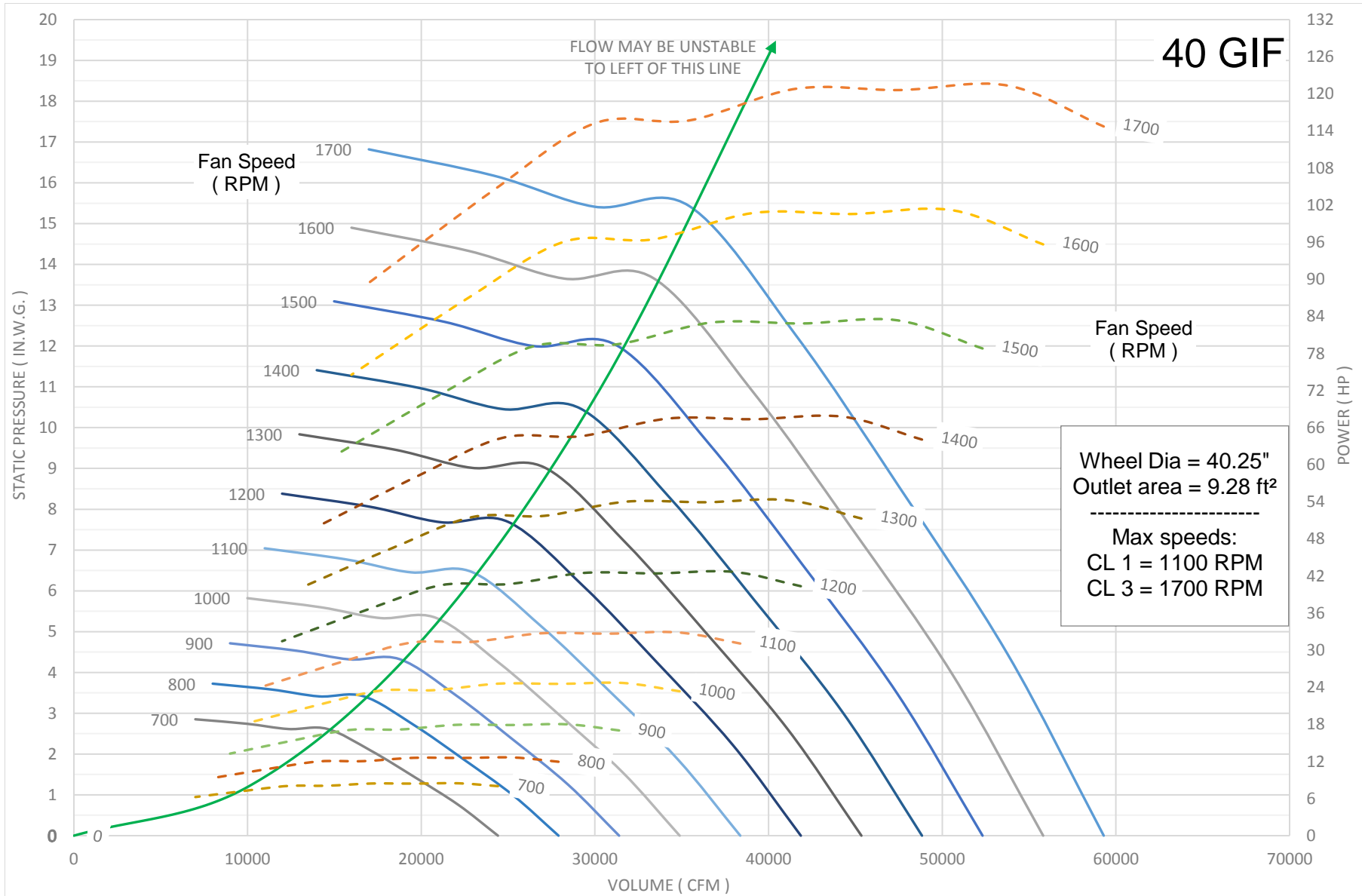

Plasticair Inc.
1275 Crestlawn Drive
Mississauga, Ontario L4W 1A9

PERFORMANCE CERTIFIED IS FOR INSTALLTION TYPE B - UNDUCTED INLET, DUCTED OUTLET
PERFORMANCE RATINGS DO NOT INLDUE THE EFFECTS OF APPARTENACES (ACCESSORIES)
POWER RATINGS DO NOT INLCLUDE TRANSMISSION LOSSES

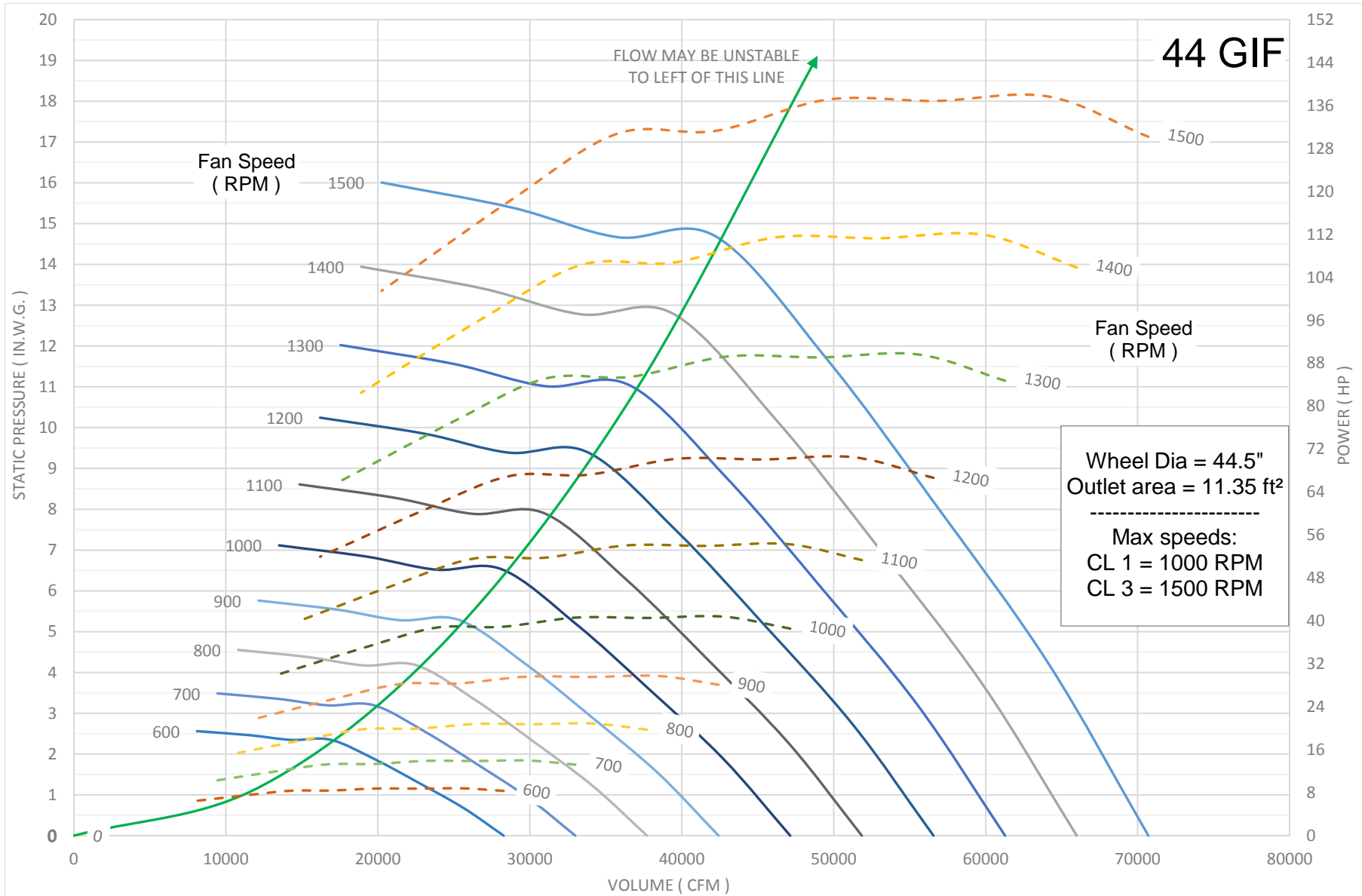

Plasticair Inc.

1275 Crestlawn Drive
Mississauga, Ontario L4W 1A9

PERFORMANCE CERTIFIED IS FOR INSTALLTION TYPE B - UNDUCTED INLET, DUCTED OUTLET.
PERFORMANCE RATINGS DO NOT INLDUE THE EFFECTS OF APPARTENACES (ACCEESSORIES).
POWER RATINGS DO NOT INLCLUDE TRANSMISSION LOSSES.

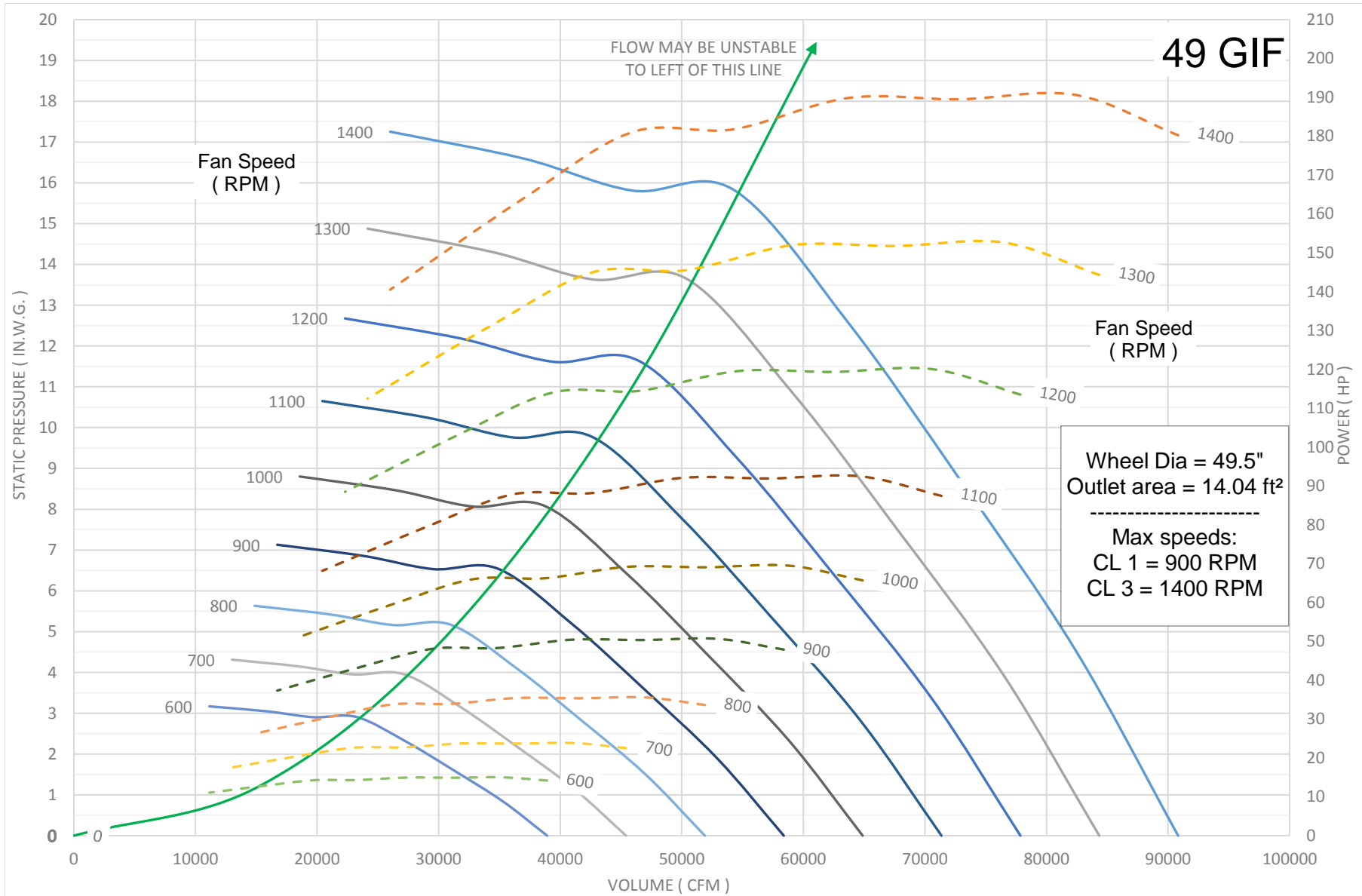

Plasticair Inc.
 1275 Crestlawn Drive
 Mississauga, Ontario L4W 1A9

PERFORMANCE CERTIFIED IS FOR INSTALLTION TYPE B - UNDUCTED INLET, DUCTED OUTLET.
 PERFORMANCE RATINGS DO NOT INLDUE THE EFFECTS OF APPARTENACES (ACCESSIONS).
 POWER RATINGS DO NOT INLCLUDE TRANSMISSION LOSSES.

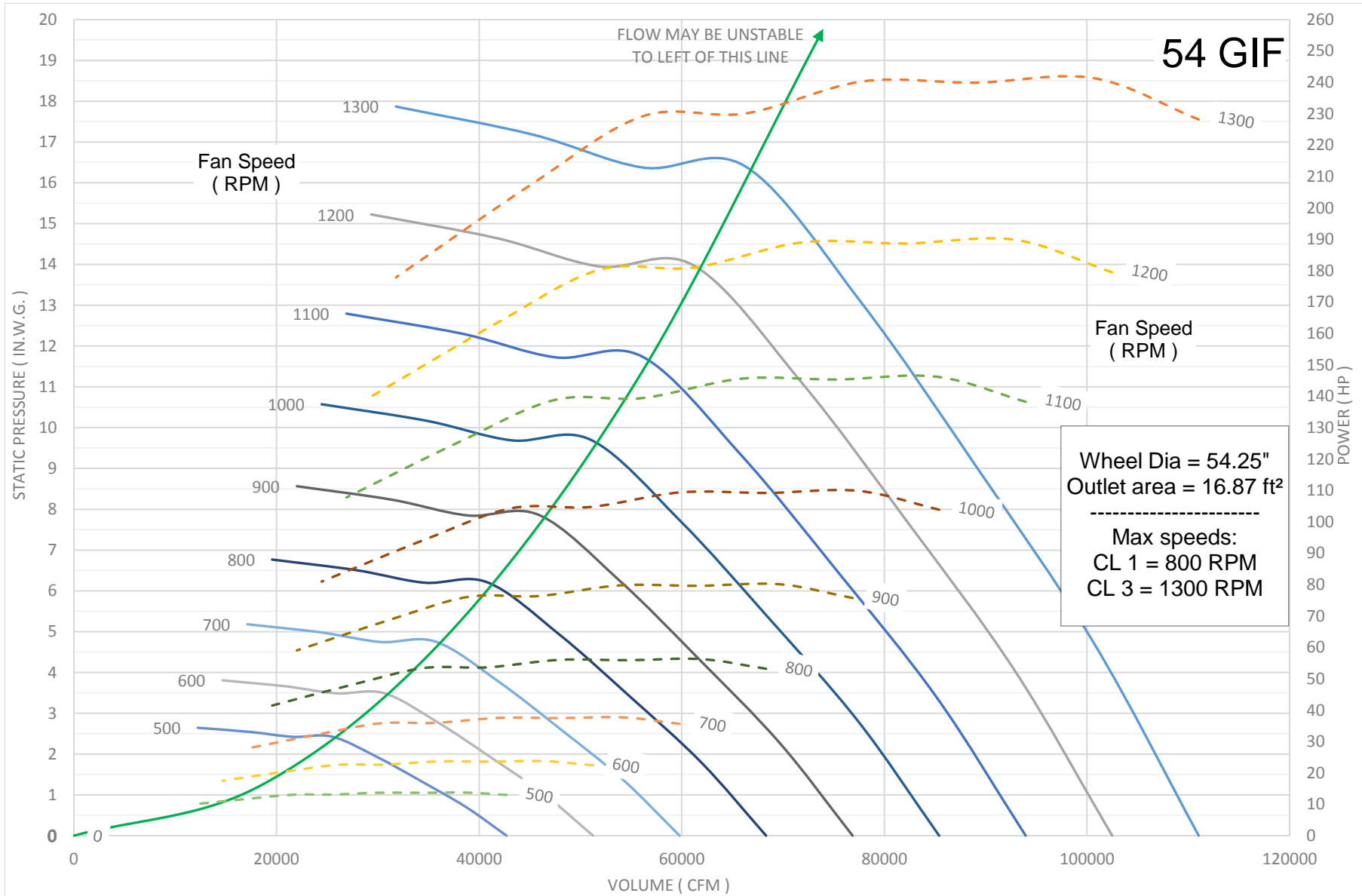

Plasticair Inc.
1275 Crestlawn Drive
Mississauga, Ontario L4W 1A9

PERFORMANCE CERTIFIED IS FOR INSTALLTION TYPE B - UNDUCTED INLET, DUCTED OUTLET.
PERFORMANCE RATINGS DO NOT INLDUE THE EFFECTS OF APPARTENACES (ACCESSIONS).
POWER RATINGS DO NOT INLCLUDE TRANSMISSION LOSSES.

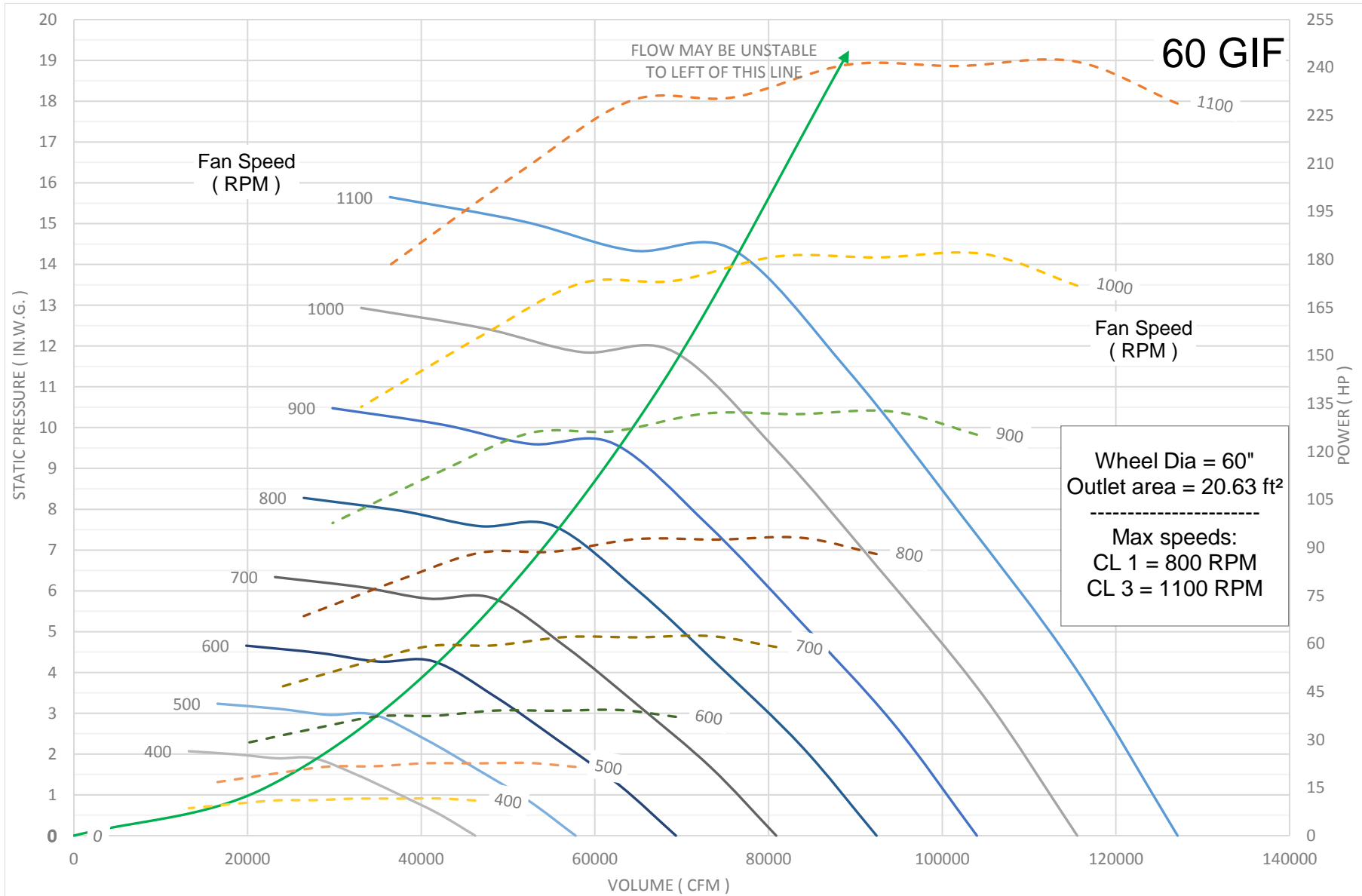

Plasticair Inc.
1275 Crestlawn Drive
Mississauga, Ontario L4W 1A9

PERFORMANCE CERTIFIED IS FOR INSTALLATION TYPE B - UNDUCTED INLET, DUCTED OUTLET.
PERFORMANCE RATINGS DO NOT INCLUDE THE EFFECTS OF APPURTENCES (ACCESSORIES).
POWER RATINGS DO NOT INCLUDE TRANSMISSION LOSSESS.

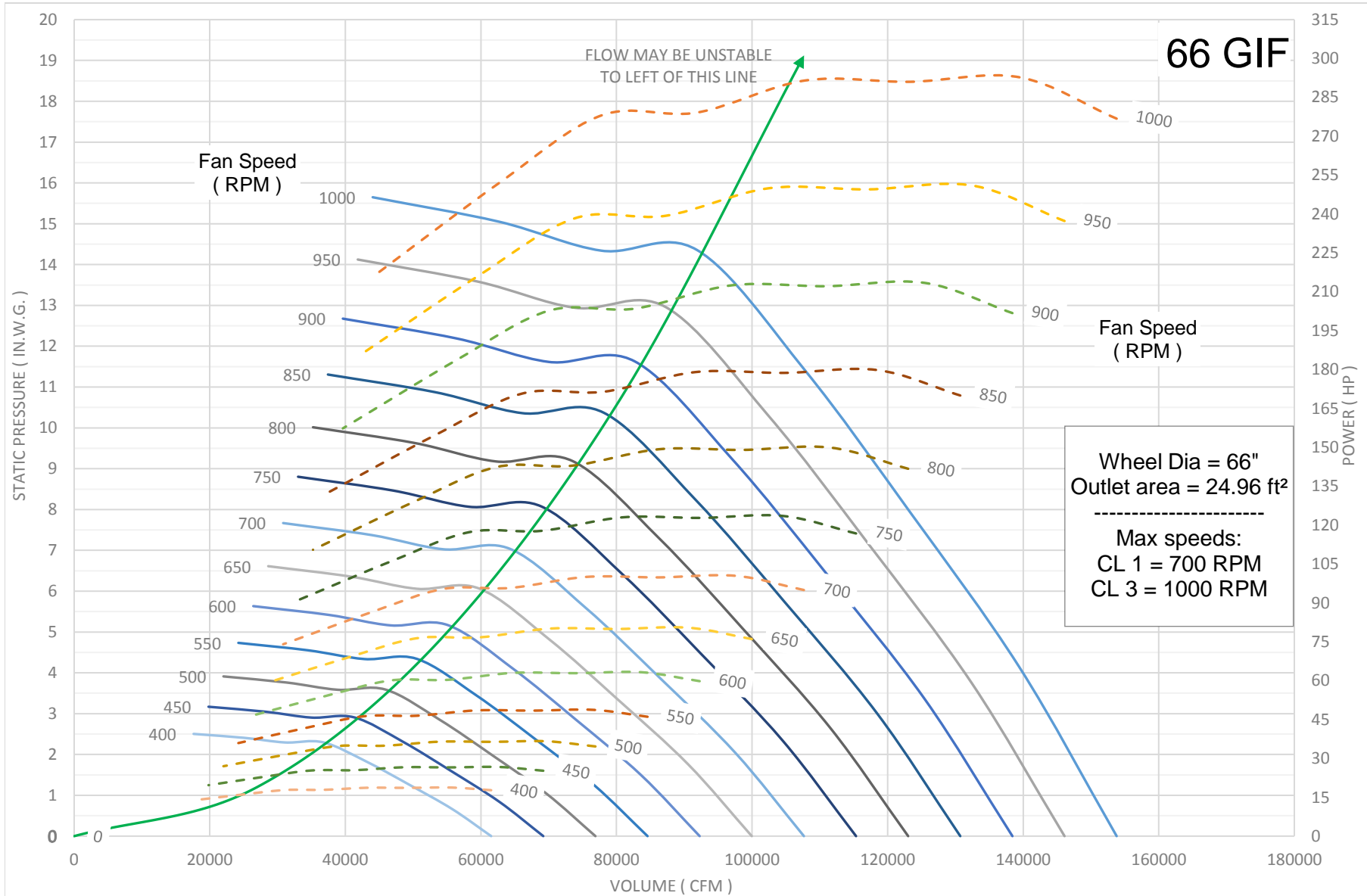

Plasticair Inc.
 1275 Crestlawn Drive
 Mississauga, Ontario L4W 1A9

PERFORMANCE CERTIFIED IS FOR INSTALLTION TYPE B - UNDUCTED INLET, DUCTED OUTLET.
 PERFORMANCE RATINGS DO NOT INLDUE THE EFFECTS OF APPARTENACES (ACCESSORIES).
 POWER RATINGS DO NOT INCLUE TRANSMISSION LOSSES.



Plasticair GIF Series Centrifugal Fans

Heavy Duty Industrial Applications

24GIF		Inlet Sound Power, Lwi (dB re 10 ⁻¹² watts)									
RPM	%WOV	1	2	3	4	5	6	7	8	LwiA	
1100	100	85	87	88	86	84	78	71	66	88	
	80	83	85	86	81	77	72	65	61	83	
	50	89	85	83	76	72	68	64	61	79	
	30	92	88	84	78	72	68	64	60	81	
1500	100	94	93	98	92	93	88	80	75	97	
	80	93	90	96	89	86	82	74	70	92	
	50	101	93	93	86	80	77	72	69	89	
	30	103	97	94	88	80	77	73	69	90	
1900	100	98	100	102	100	98	95	88	82	103	
	80	97	98	100	97	92	89	82	77	98	
	50	105	102	99	94	87	83	79	75	96	
	30	107	106	101	96	88	83	80	76	98	
2300	100	101	106	106	106	102	100	94	87	108	
	80	100	104	103	103	97	94	88	82	104	
	50	108	110	104	100	93	88	84	80	102	
	30	110	113	107	102	94	88	85	81	104	
2700	100	104	110	109	111	105	105	100	92	112	
	80	103	109	106	109	102	98	94	86	109	
	50	111	116	108	106	98	92	89	84	107	
	30	113	119	112	107	100	92	89	85	109	

27GIF		Inlet Sound Power, Lwi (dB re 10 ⁻¹² watts)									
RPM	%WOV	1	2	3	4	5	6	7	8	LwiA	
1000	100	86	89	88	87	84	77	71	66	88	
	80	84	87	86	81	78	71	66	62	83	
	50	89	86	83	77	72	68	64	61	80	
	30	92	88	84	77	72	69	65	61	81	
1375	100	95	95	98	93	93	88	80	75	97	
	80	94	92	96	90	87	82	75	71	93	
	50	101	94	93	86	81	77	73	70	89	
	30	104	98	94	88	81	78	74	70	91	
1750	100	100	101	104	100	99	95	88	82	104	
	80	99	99	102	97	93	89	82	77	99	
	50	107	103	100	94	88	84	79	76	97	
	30	109	106	102	96	88	84	80	76	98	
2125	100	104	107	108	106	103	101	95	88	109	
	80	103	105	105	104	98	95	89	83	105	
	50	111	110	105	101	94	89	85	81	103	
	30	113	113	108	102	95	89	86	82	104	
2500	100	107	112	111	112	107	106	100	93	113	
	80	106	110	108	109	103	99	94	87	109	
	50	114	117	109	106	99	93	90	85	108	
	30	116	119	113	108	100	93	90	86	110	

30GIF		Inlet Sound Power, Lwi (dB re 10 ⁻¹² watts)									
RPM	%WOV	1	2	3	4	5	6	7	8	LwiA	
900	100	87	91	88	88	84	77	71	66	89	
	80	84	89	85	82	78	71	66	62	84	
	50	88	87	82	77	73	68	65	62	80	
	30	92	89	84	77	73	69	65	61	81	
1225	100	96	97	98	94	93	87	80	75	97	
	80	94	94	96	90	87	81	75	71	93	
	50	101	95	93	86	81	77	73	70	89	
	30	103	98	94	88	81	78	74	70	91	
1550	100	102	101	105	99	100	95	87	82	104	
	80	101	98	103	96	93	89	81	77	99	
	50	109	102	101	93	87	84	79	76	96	
	30	111	105	102	95	87	84	80	76	98	
1875	100	106	107	109	106	104	101	94	88	109	
	80	105	105	107	103	98	94	88	82	104	
	50	113	109	105	100	93	89	85	81	102	
	30	115	113	107	102	94	89	85	81	104	
2200	100	108	112	112	111	107	105	99	92	113	
	80	107	110	109	108	102	99	93	87	109	
	50	115	116	110	105	98	93	89	85	107	
	30	117	118	112	107	99	93	90	86	109	

33GIF		Inlet Sound Power, Lwi (dB re 10 ⁻¹² watts)									
RPM	%WOV	1	2	3	4	5	6	7	8	LwiA	
800	100	87	92	87	88	84	76	71	66	89	
	80	84	90	85	82	78	70	66	62	83	
	50	87	87	82	76	73	68	65	62	79	
	30	91	89	83	76	73	69	65	61	80	
1100	100	96	98	98	95	93	87	80	75	97	
	80	94	95	95	90	87	81	75	71	92	
	50	100	96	92	86	81	77	73	70	89	
	30	103	98	94	87	81	78	74	70	90	
1400	100	103	102	106	100	100	95	87	82	104	
	80	102	99	103	96	93	89	81	77	99	
	50	109	102	100	93	87	84	79	76	96	
	30	112	106	102	95	87	84	80	76	98	
1700	100	107	107	110	105	105	101	93	88	109	
	80	106	105	108	103	98	95	87	82	105	
	50	114	109	106	100	93	89	85	81	102	
	30	116	112	108	101	93	89	86	81	104	
2000	100	110	112	113	111	108	105	99	92	113	
	80	109	110	111	108	103	99	93	87	109	
	50	117	115	110	105	98	94	89	86	107	
	30	119	118	112	107	99	94	90	86	109	

The sound power level ratings shown are in decibels, referred to 10⁻¹² watts calculated per AMCA Standard 301. Values shown are for inlet Lwi and LwiA sound power levels for Installation Type B: Unducted inlet, ducted outlet. Ratings do not include the effects of duct end correction.

Plasticair Inc.
 1275 CRESTLAWN DRIVE
 MISSISSAUGA, ONTARIO, CANADA L4W 1A9
 TEL: (905) 625-9164 FAX: (905) 625-0147



Plasticair GIF Series Centrifugal Fans

Heavy Duty Industrial Applications

36GIF		Inlet Sound Power, Lwi (dB re 10 ⁻¹² watts)									
RPM	%WOV	1	2	3	4	5	6	7	8	LwiA	
700	100	87	92	87	88	83	75	70	65	88	
	80	84	90	84	81	77	69	65	61	83	
	50	87	87	81	75	72	67	64	61	79	
	30	90	88	82	75	72	68	64	60	80	
975	100	96	99	97	96	93	86	80	75	97	
	80	94	97	94	90	86	80	74	70	92	
	50	99	96	91	85	81	77	73	70	88	
	30	102	98	93	86	81	77	73	69	90	
1250	100	103	104	105	101	100	94	87	82	104	
	80	102	101	103	97	93	88	81	77	99	
	50	109	102	100	93	87	84	79	76	96	
	30	111	106	101	94	87	84	80	76	97	
1525	100	109	108	111	105	106	101	93	88	110	
	80	108	105	109	102	99	95	87	83	105	
	50	116	108	106	99	93	90	85	82	102	
	30	118	112	108	101	93	90	86	82	104	
1800	100	112	112	114	110	109	105	98	92	114	
	80	111	110	112	108	103	99	92	87	109	
	50	119	114	111	105	98	94	89	86	107	
	30	121	118	112	106	98	94	90	86	109	

40GIF		Inlet Sound Power, Lwi (dB re 10 ⁻¹² watts)									
RPM	%WOV	1	2	3	4	5	6	7	8	LwiA	
700	100	91	95	90	91	86	78	73	68	91	
	80	88	93	87	84	80	72	68	64	86	
	50	90	90	84	78	75	70	67	64	82	
	30	94	91	85	78	75	71	67	63	83	
950	100	99	102	99	98	95	88	82	77	100	
	80	97	100	97	92	89	82	77	73	94	
	50	101	99	94	87	83	79	75	72	91	
	30	105	101	95	88	83	80	76	72	92	
1200	100	106	106	107	103	102	96	89	84	106	
	80	104	104	105	99	95	90	83	79	101	
	50	111	105	102	95	89	86	81	78	98	
	30	113	108	103	96	89	86	82	78	99	
1450	100	111	110	113	107	107	102	94	89	111	
	80	110	107	111	104	100	96	88	84	107	
	50	118	110	108	100	94	91	86	83	104	
	30	120	113	109	102	94	91	87	83	105	
1700	100	115	114	116	111	111	107	99	94	115	
	80	114	111	114	109	105	101	93	89	111	
	50	122	115	112	106	99	95	91	87	109	
	30	124	119	114	107	99	95	92	88	110	

44GIF		Inlet Sound Power, Lwi (dB re 10 ⁻¹² watts)									
RPM	%WOV	1	2	3	4	5	6	7	8	LwiA	
600	100	92	94	90	90	84	77	72	67	90	
	80	89	91	86	83	78	71	67	63	84	
	50	90	88	82	77	74	69	66	63	81	
	30	93	90	83	77	74	70	66	62	81	
825	100	98	103	98	98	94	86	81	76	99	
	80	96	101	95	92	88	80	76	72	94	
	50	99	98	92	86	83	78	75	72	90	
	30	103	100	94	86	83	79	75	71	91	
1050	100	106	107	106	103	101	94	88	83	105	
	80	103	105	103	98	94	88	82	78	100	
	50	109	105	100	94	89	85	81	78	97	
	30	112	107	102	95	89	85	81	77	98	
1275	100	111	111	112	107	107	101	93	88	111	
	80	110	108	110	103	100	95	88	84	106	
	50	117	110	107	100	94	90	86	83	103	
	30	119	113	108	101	94	91	87	83	104	
1500	100	116	114	117	111	111	106	98	93	115	
	80	115	111	115	108	104	100	92	88	111	
	50	123	114	112	105	98	95	90	87	108	
	30	125	118	113	107	98	95	91	87	110	

49GIF		Inlet Sound Power, Lwi (dB re 10 ⁻¹² watts)									
RPM	%WOV	1	2	3	4	5	6	7	8	LwiA	
500	100	92	91	90	87	80	74	69	64	88	
	80	89	89	84	81	74	69	65	61	82	
	50	89	86	79	75	71	67	64	61	78	
	30	91	87	80	75	72	68	64	60	79	
700	100	98	102	97	97	92	84	79	74	97	
	80	95	100	93	90	86	78	74	70	92	
	50	97	97	90	84	81	76	73	70	88	
	30	101	98	92	84	81	77	73	69	89	
900	100	104	108	104	103	99	92	86	81	104	
	80	102	105	101	97	93	86	81	77	99	
	50	106	104	98	92	88	83	80	77	95	
	30	110	106	100	92	88	84	80	76	97	
1100	100	110	111	110	107	105	99	92	87	110	
	80	109	109	108	102	99	93	87	83	105	
	50	114	109	105	98	93	89	85	82	101	
	30	117	112	106	99	93	90	86	82	103	
1300	100	115	114	116	111	110	104	97	92	114	
	80	114	112	114	107	103	98	91	87	110	
	50	121	113	111	103	97	94	89	86	107	
	30	123	117	112	105	97	94	90	86	108	

The sound power level ratings shown are in decibels, referred to 10⁻¹² watts calculated per AMCA Standard 301. Values shown are for inlet Lwi and LwiA sound power levels for Installation Type B: Unducted inlet, ducted outlet. Ratings do not include the effects of duct end correction.

Plasticair Inc.
 1275 CRESTLAWN DRIVE
 MISSISSAUGA, ONTARIO, CANADA L4W 1A9
 TEL: (905) 625-9164 FAX: (905) 625-0147



Plasticair GIF Series Centrifugal Fans

Heavy Duty Industrial Applications

54GIF		Inlet Sound Power, Lwi (dB re 10 ⁻¹² watts)									
RPM	%WOV	1	2	3	4	5	6	7	8	LwiA	
500	100	95	94	93	90	84	77	72	67	91	
	80	93	92	87	84	78	72	68	64	85	
	50	92	89	83	79	74	71	68	65	81	
	30	95	90	84	79	75	71	67	63	82	
675	100	101	104	99	99	94	86	81	76	100	
	80	98	102	95	92	88	80	76	72	94	
	50	100	99	92	86	83	78	75	72	90	
	30	104	100	94	86	83	79	75	71	91	
850	100	106	110	105	105	101	93	88	83	106	
	80	104	108	102	99	95	87	83	79	101	
	50	108	106	99	93	89	85	81	78	97	
	30	111	107	101	93	89	86	82	78	98	
1025	100	112	113	111	109	106	100	93	88	111	
	80	110	111	109	104	100	94	88	84	106	
	50	115	111	106	99	94	90	86	83	103	
	30	118	113	107	100	94	91	87	83	104	
1200	100	117	116	116	112	111	105	98	93	115	
	80	115	114	114	108	104	99	92	88	110	
	50	121	115	111	104	98	95	90	87	107	
	30	124	118	112	105	98	95	91	87	109	

60GIF		Inlet Sound Power, Lwi (dB re 10 ⁻¹² watts)									
RPM	%WOV	1	2	3	4	5	6	7	8	LwiA	
400	100	95	91	91	87	79	74	69	64	88	
	80	93	88	85	81	73	69	65	61	82	
	50	90	85	79	76	71	68	65	62	78	
	30	91	87	79	76	72	68	64	60	79	
575	100	102	102	99	98	91	84	79	74	98	
	80	99	100	94	91	85	79	75	71	93	
	50	100	97	90	85	81	77	74	71	89	
	30	103	98	91	85	82	78	74	70	89	
750	100	107	111	104	105	100	92	87	82	106	
	80	104	109	101	98	94	86	82	78	100	
	50	107	106	98	92	89	84	81	78	97	
	30	111	107	100	92	89	85	81	77	97	
925	100	113	115	111	110	106	99	93	88	111	
	80	110	113	108	104	100	93	88	84	106	
	50	115	111	105	99	95	90	87	84	103	
	30	118	113	107	99	95	91	87	83	104	
1100	100	118	118	117	113	111	105	98	93	116	
	80	116	116	114	109	105	99	93	89	111	
	50	122	116	111	104	99	95	91	88	108	
	30	125	119	113	105	99	96	92	88	109	

66GIF		Inlet Sound Power, Lwi (dB re 10 ⁻¹² watts)									
RPM	%WOV	1	2	3	4	5	6	7	8	LwiA	
400	100	95	91	91	87	79	74	69	64	88	
	80	92	87	83	80	73	69	65	61	81	
	50	94	90	80	76	73	68	62	57	80	
	30	95	92	80	76	74	68	61	54	81	
550	100	104	104	101	99	93	86	81	76	100	
	80	101	101	96	93	87	81	77	73	94	
	50	102	98	92	87	83	79	76	73	90	
	30	104	100	93	87	83	80	76	72	91	
700	100	108	112	106	106	101	93	88	83	107	
	80	105	110	102	99	95	87	83	79	101	
	50	108	107	99	93	90	85	82	79	97	
	30	111	108	101	93	90	86	82	78	98	
850	100	113	116	111	111	107	99	94	89	112	
	80	111	114	108	105	101	93	89	85	107	
	50	114	112	105	99	95	91	87	84	103	
	30	118	114	107	99	95	92	88	84	104	
1000	100	118	119	117	114	111	105	98	93	116	
	80	116	117	114	109	105	99	93	89	111	
	50	121	116	111	104	100	95	92	89	108	
	30	124	119	113	105	100	96	92	88	109	

The sound power level ratings shown are in decibels, referred to 10⁻¹² watts calculated per AMCA Standard 301. Values shown are for inlet Lwi and LwiA sound power levels for Installation Type B: Unducted inlet, ducted outlet. Ratings do not include the effects of duct end correction.

Plasticair Inc.
 1275 CRESTLAWN DRIVE
 MISSISSAUGA, ONTARIO, CANADA L4W 1A9
 TEL: (905) 625-9164 FAX: (905) 625-0147



Plasticair GIF Series Centrifugal Fans

Heavy Duty Industrial Applications

How To Specify Plasticair Backward Inclined Fans – GIF Series

General

The fan is to be designed and constructed so that the corrosive gas stream only contacts solid FRP surfaces. All steel fasteners within the corrosive gas contact area will be stainless steel and encapsulated with a minimum of 0.1875" (3 mm) of FRP lay-up. The manufacturer must supply fans with RPM and BHP equal to or less than that shown in the fan schedule. The acceptable AMCA arrangements are 1, 4, 9 and 10 as indicated on the fan schedule. Under no circumstances shall an impeller or motor shaft be exposed to the corrosive gas stream. All shafts will be fully protected with FRP shaft sleeves. The fan shall be constructed as per AMCA Standards 99. Fans shall conform to ATSM D 4167 - 91.

Air Performance

The performance ratings are to be in accordance with AMCA standard 210, and the fans must bear the AMCA Air & Sound Performance Seal.

Sound Data

Submitted sound data shall be in accordance with AMCA standards 300 and 301. All submitted data will be in decibels re 10-12 watts, and presented in eight octave bands.

Impeller Construction

All resin is to be clear (no pigments) in order to expose any imperfections or unauthorized fillers. The impeller is to be of a high efficiency backward inclined or backward curved design. The material of construction is to be vinyl ester resin (premium quality Hetron 922) and reinforcing glass throughout. The method of construction is to be hand lay-up only. Injection molded, rotor molded or press molded techniques are not acceptable. The entire surface of the impeller exposed to the gas stream will be complete with a resin rich corrosion barrier consisting of C-veil and a smooth finish. The shaft is to be attached to the back-plate of the impeller by way of a taper lock bushing and a one piece cast sprocket hub. Sprockets with welded hubs are not acceptable. The entire shaft attachment assembly is to be completely covered with a minimum 0.25"(6 mm) of FRP lay-up. Steel or thermoplastic impellers with FRP coatings are not acceptable.

Housing Construction

The fan housing is to be designed and constructed to resist vibration for static pressures up to 19" W.G. The material of construction will be vinyl ester resin (premium quality Hetron 922) and reinforcing glass throughout. The method of construction will be hand lay-up only. The entire surface exposed to the corrosive gas stream will be complete with a resin rich corrosion barrier consisting of C-veil and a smooth finish. The outer surface of the housing will be a heavy gel coat, UV stabilized coating. The fan housing is to be of a bolted center split design complete with neoprene gasket for easy impeller access. All Flanges are to have factory flat finishes. The inlet is to be slip fit connection. The housing shall consist of a machined Teflon seal to limit gas leakage. Steel and thermoplastic housings complete with or without FRP linings are not acceptable.

Steel Fan Base

The fan base is to be of heavy-duty industrial quality to minimize vibration and to ensure long life. The bearing shaft pedestal is to be constructed of heavy gauge steel. The fabrication method is to be all welded. If a unitary motor mounting base (arrangement 1) is required, the bearing and shaft pedestal is to be attached by welding. After welding is complete, prior to the fan assembly, the fan base is to be coated with 2-4 mils of the manufacturers standard epoxy.

Bearings

Bearings are to be solid pillow block, self-aligning type. The bearings are to be rated and designed for a minimum L-10 life of 50,000 hours or L-50 life of 200,000 hours. The bearings are to be located out of the air stream and are to be covered with an easily removable guard for maintenance access. The method of lubrication will be grease.

Shaft

Fan shaft will be 1045 carbon steel. The diameter of the shaft shall be sized to ensure that the critical speed of the fan is at least 25% above the fan operating speed. The drive side of the shaft shall be countersunk for tachometer readings and complete with the correct keyways to accept V-belt drive selections. The impeller side of the shaft shall be complete with an FRP shaft sleeve which is bonded to the back-plate of the impeller and protrudes past the Teflon shaft seal located on the on the housing.

Balancing and Testing

Balancing of the impeller shall be achieved only with the use of the identical material used to fabricate the impeller. The use of any other foreign material is not acceptable. The balancing shall be in accordance with ASTM D-4167. The fan shall be test run and not shipped until vibration readings are within acceptable limits.

Warranty

The supplier shall warrant that all fan components shall be free from defects in materials and workmanship for a period of 15 months from date shipped or 12 months from equipment start up, which ever occurs first.

Acceptable Manufacturers

Plasticair Inc. or approved equal

Plasticair Inc.
1275 CRESTLAWN DRIVE
MISSISSAUGA, ONTARIO, CANADA L4W 1A9
TEL: (905) 625-9164 FAX: (905) 625-0147

Plasticair Inc., Servicing Industry

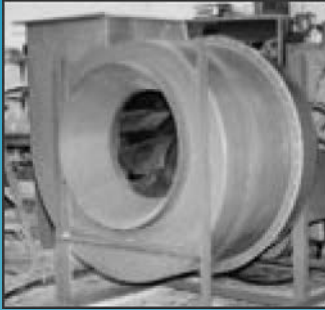

FRP Fans

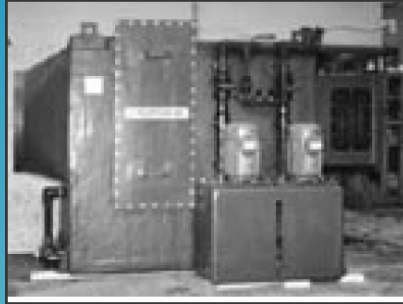

Scrubbing Equipment

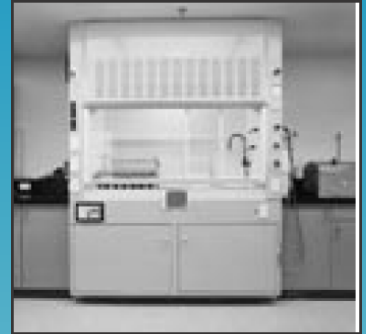

Laboratory Fumehoods

Plasticair Product List

Scrubbers:

Horizontal Packed Bed - Single/Double (HS-Series)
Vertical Packed Bed Towers (VS-Series)
Odour Control Scrubbers (HCS, VCS-Series)
Demisters - Vane Type (P-Series)
Demisters - Mesh Type (M-Series)
Demisters - Multiple Stage Type (E-Series)
Venturi Scrubbers (ECE-Series)
Laboratory Fume Hood Scrubbers (FHS-Series)

Scrubber Applications:

Oil/Air Separators
Chlorine Scrubbers
Micro Chip Manufacturing Scrubbers
Plating Plant Scrubbers
Pickling Line Scrubbers
Chromic Acid Scrubbers And Demisters

FRP Fans:

Axial Fans - Vane / Tube
Panel Fans - Wall Mount / Box Mount
Inline Centrifugal - Backward Curved
Laboratory Fans - B.I. Utility Sets / B.I. Tubular
High Pressure Fans - Radial Blade
Medium Pressure Fans - Radial Blade
Medium Pressure Fans - Backward Curved
Mini Industrial Vent Sets - Radial Blade / B.I.

Plasticair's Sales Forces are located in major cities around the world.



Contact the factory for the agent closest to you.

Your local Plasticair Representative is:



Plasticair Inc.
1275 CRESTLAWN DRIVE,
MISSISSAUGA, ONTARIO, CANADA L4W 1A9
TEL: (905) 625-9164 FAX: (905) 625-0147

Bulletin #110
October, 2012